

3D VIEW

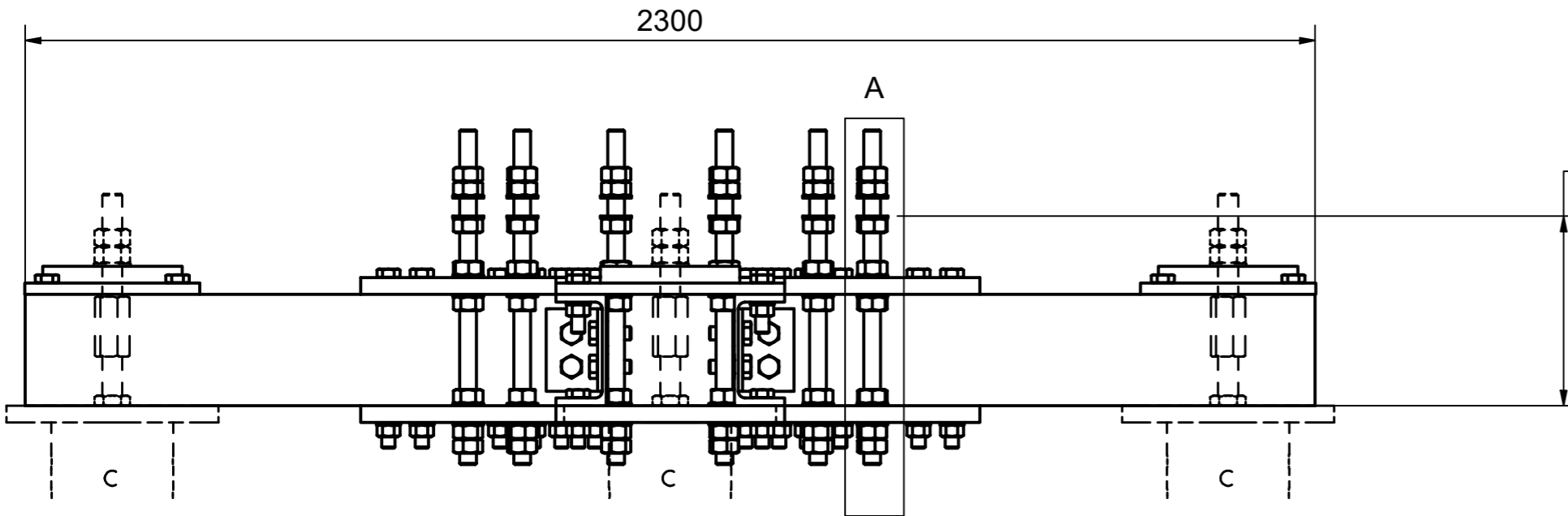

340 TOP OF PILE CAP  
TO UNDERSIDE OF  
MONOPOLE

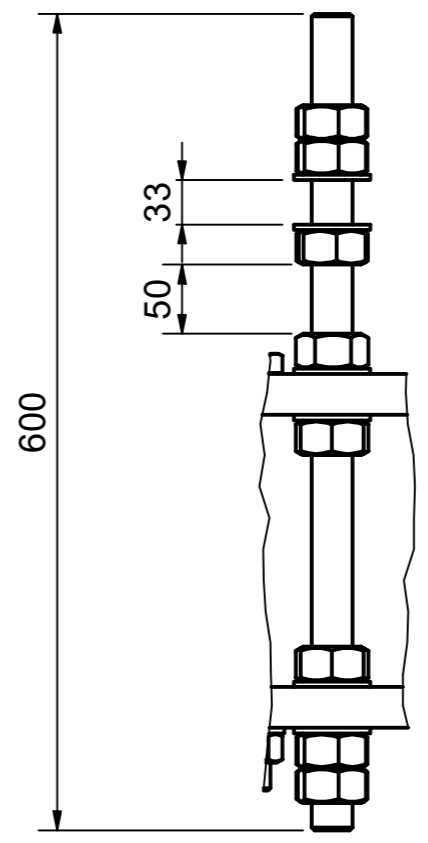

DETAIL A

| FRAME NUMBER | COMPATIBLE TOWER TYPES   | FRAME CAPACITY |       |        | MAXIMUM DEFLECTION |
|--------------|--|----------------|-------|--------|--------------------|
|              |  | OTM            | SHEAR | WEIGHT |                    |
| HPF295       | 20m ORION MONOPOLE,<br>20m APOLLO MONOPOLE,<br>20m ATLAS MONOPOLE,<br>M-RANGE MONOPOLE | 215 kNm        | 16 kN | 37 kN  | 0.41°              |

|       |            |              |      |      |
|-------|------------|--------------|------|------|
| A     | 06/01/2026 | FIRST ISSUE  | JDG  | MN   |
| ISSUE | DATE       | MODIFICATION | DSNR | CHKD |



|                      |            |               |     |               |     |
|----------------------|------------|---------------|-----|---------------|-----|
| DATE                 | 07/01/2026 | SCALE         | NTS | FLI Ref       | N/A |
| DRAWN /<br>ISSUED BY | JDG        | DRG.<br>CHECK | HN  | ENG.<br>APP'D | --  |

|          |                  |
|----------|------------------|
| CUSTOMER | STANDARD PRODUCT |
|----------|------------------|

|           |     |
|-----------|-----|
| ORDER No. | N/A |
|-----------|-----|

|       |  |
|-------|--|
| TITLE | T-FRAME GRILLAGE TO SUIT 20m<br>STREETWORKS MONOPOLE |
|-------|--|