

## GUIDANCE NOTES FOR TIGHTENING NON-PRELOADED (ORDINARY) BOLTS

MD030 Rev1.2

Revision	Modification	Date	Prepared By	Checked By	Status
-	-	22/05/2018	Trevor Burden	-	For Comment
1.1	-	31/05/2018	Trevor Burden	Richard Steel	1st Issue
1.2	Explicit notes on pre-assembly site tightness check added, Impact Wrench values also for Torque Wrenches, Torque values standardised.	20/11/2024	Trevor Burden	Richard Steel	2nd Issue

## CONTENTS

<b>1</b>	<b>INSTALLATION GUIDANCE</b> .....	<b>2</b>
<b>2</b>	<b>BOLT CONFIGURATION</b> .....	<b>2</b>
<b>3</b>	<b>BOLT LENGTH</b> .....	<b>2</b>
<b>4</b>	<b>CORROSION PROTECTION</b> .....	<b>2</b>
<b>5</b>	<b>BOLT TIGHTENING – NON-PRELOADED (ORDINARY) BOLTS</b> .....	<b>2</b>
5.1	1 <sup>st</sup> Stage Bolt Tightening .....	2
5.2	2 <sup>nd</sup> Stage Bolt Tightness Check .....	3
<b>6</b>	<b>MAINTENANCE TIGHTNESS CHECK</b> .....	<b>3</b>
<b>7</b>	<b>PRE-ASSEMBLED MODULES FOLLOWING TRANSPORT</b> .....	<b>3</b>
<b>8</b>	<b>HARDLOCK NUTS – INSTALLATION AND TIGHTENING</b> .....	<b>3</b>
<b>9</b>	<b>PAL NUTS – INSTALLATION AND TIGHTENING</b> .....	<b>5</b>
<b>10</b>	<b>DESIGNERS STATEMENT OF RESIDUAL HAZARDS</b> .....	<b>6</b>

## 1 INSTALLATION GUIDANCE

Refer to the relevant General Arrangement drawings for details of the tower layout, elements and fixings used on the structure. Refer to the relevant Method Statement and Risk Assessment for the assembly and erection sequence of the structure.

The vast majority of structural bolts on FLI's structures are designed as non-preloaded bolts (ordinary/un-torqued). These guidance notes are only appropriate for non-preloaded bolts.

High Strength Friction bolts (HSFG, Non-Slip) bolts are occasionally utilised. Where HSFG bolts are used, these guidance notes do not apply and a tightening method appropriate to the bolt type must be formulated and used.

## 2 BOLT CONFIGURATION

Bolt assemblies supplied by FLI Structures typically comprise a Bolt (Grade 8.8 spun galvanised to BS EN ISO 10684:2004), Nut and Flat Washer for use under the nut. Spring washers are not supplied, nor desired. If spring washers are found on site they must be discarded. Bolts are supplied "dry", i.e. not lubricated. Any quoted torques apply to bolts in this condition.

All bolts shall be fitted such that the nut is underneath. This ensures that if for any reason a nut worked loose the bolt would remain in place. The only exception is where the bolts can only be fitted the other way around.

U-Bolts and N-Bolts are typically Grade 4.6. and comprise the shaft, and one washer and 2 nuts per threaded end, the second nut being used as a lock nut.

Special bolts, fixings and configurations are utilised from time to time, such as Hardlock Nuts and PAL nuts, as detailed on the structure specific General Arrangement Drawing. Where special fixings are supplied, appropriate tightening methods must be used.

## 3 BOLT LENGTH

Bolts have been selected to give a minimum thread projection in accordance with the National Structural Steelwork Specification 4th Edition, pg. 41, clause 6.1.4, which states:

'Bolt length shall be chosen such that, after tightening at least one clear thread projects past the nut'

It is therefore important that the correct bolts are used in each connection. FLI's assembly drawings give details of which nuts and bolts are to be used and the quantities of each size required are supplied in individual labelled bags with the tower.

## 4 CORROSION PROTECTION

Bolts and other structural fasteners are typically spun galvanised and as such have an average coating thickness of 50µm (For more information, also see ISO 10684:2004). This may equate to a lower design life than the structure and so the bolts on the structure may have to be replaced, depending on the actual corrosion rate. This can be controlled via the inspection regime.

## 5 BOLT TIGHTENING – NON-PRELOADED (ORDINARY) BOLTS

- Component parts should be identified & collated, using the packing list.
- Components should be assembled, in accordance with the assembly drawings, typically on blocks on a level surface.
- A dimensional check of the assembly should be carried out, before tightening the bolts.

### 5.1 1<sup>st</sup> Stage Bolt Tightening

- The bolts should be fully tightened using an impact driver and spanner or 2 spanners.

For structural bolts designed as ordinary, non-preloaded bolts the following guidance applies.

Initial tightening shall be by hand to the following method.

"Bolts shall be made "snug tight" being that tightness achievable by the effort of one man using a normal

sized spanner without an extension arm and can be set as the point at which a percussion wrench starts hammering.” Ref Eurocode standard for Execution of Steel Structures BS EN 1090-2 Cl 8.3 note 2:

- Caution must be exercised if using percussion wrenches. Many modern models can apply well in excess of 250Nm, which will certainly overstress bolts and strip threads. It is essential that the correct model of percussion wrench is chosen and that it is suitably calibrated for the task at hand. **If calibration of percussion wrenches is not possible, then they shall not be used.**
- The following table provides the recommended torques to be applied by percussion wrenches and torque wrenches:

Bolt Designation	Bolt Grade	
	4.6	8.8 & 10.9
	Torque (Nm)	
M12	30	65
M16	60	100
M20	110	135
M24	130	135
M30	180	250
M36	250	250
M42	250	250

Table 1 - Recommended Torque Settings - Percussion and Torque Wrenches

- Maximum permissible torques applied by percussion wrenches and torque wrenches are shown in Section 10, Table 3.

## 5.2 2<sup>nd</sup> Stage Bolt Tightness Check

- 2nd stage Bolt tightness checks shall be done after a minimum of 1 hour, although the longer this can be delayed, the better, ideally 5 days.
- All bolts should undergo the 2nd Stage bolt tightness check and marked with a **RED** marker on the bolt head by the checker.
- Pre-assembled bolts have a **BLACK** mark to indicate they have been checked in the Works (Ref FLI QP15). Thus, all bolts shall either have a **RED** mark to indicate a site assembly and tightness check or a **BLACK** and a **RED** mark to indicate a works and site tightness check.

2nd Stage tightening shall either be by hand as describe above, or if desired, with a torque wrench Using the same values as Table 1 above.

## 6 MAINTENANCE TIGHTNESS CHECK

If, during maintenance operations, bolts are to be checked with a torque wrench to validate tightness, then use the same values as Table 1 above.

## 7 PRE-ASSEMBLED MODULES FOLLOWING TRANSPORT

All pre-assembled units that have been transported shall be considered as if the bolts have not been tightened. This is because the rigors of transit may loosen bolts. A full retightening sequence must be followed, as if the unit has been assembled on site.

## 8 HARDLOCK NUTS – INSTALLATION AND TIGHTENING

Hardlock nuts require specific installation methods to be followed.

Providing the guidance for the installation of these nuts are followed, there is no requirement for a final check on the structural bolt positions. This is because the methods of installation in this document require tightness checks to be completed during the installation process.

Hardlock nuts consist of two separate nuts which when tightened correctly provide an effective locking to any structural fastener.

The nuts are supplied loose, and each assembly consists of two separate items. The lower nut has an eccentric cone, which is proud of one of the faces of the nut. The upper nut has a concentric recess machined in one of its faces.

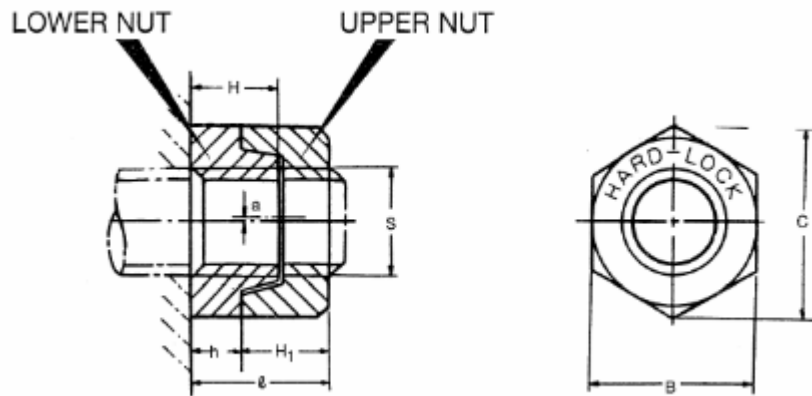





Whilst the tower modules are on the ground, fit the bolt through the parts to be connected and then fit a standard flat washer and the Hard Lock lower nut. It is essential that the lower nut be fitted with the smooth face flush to the washer and fully tightened. Tighten using the 1st stage tightening guidance given above.

Once the tower has been lifted into position and at least 1 hour after 1st stage tightening, the lower nut should be checked for tightness, using the 2nd stage tightening guidance given above.

Then fit the upper nut on the assembly ensuring that the recess in the upper nut will fit over the cone in the lower nut. Using a torque wrench tighten the upper nut to at least the minimum seating torque shown in Table 2.

Pre-assembled tower modules will not have the upper nut fitted when delivered to site. These should be fitted once the tower has been lifted into position and the lower nuts have been checked as above.

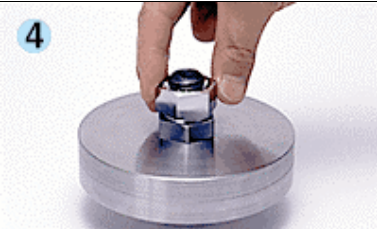
Note: Providing the torque settings have been achieved, there is no need tighten until the gap between upper and lower nuts is fully closed or to make the flat faces of the nuts to coincide.

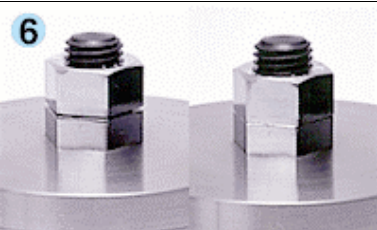
<p><b>1</b></p>  <p>Pass the bolt through the materials to be attached and screw the lower (convex) nut onto the bolt.</p>	<p><b>2</b></p>  <p>Fully tighten using 1<sup>st</sup> stage tightening guidance above</p>
<p><b>3</b></p>  <p>At this point, the lower nut has exactly the same strength as a general-purpose nut.</p>	<p><b>4</b></p>  <p>Next, screw the upper (concave) nut onto the bolt by hand.</p>
<p><b>5</b></p>  <p>After tightening the upper nut by hand, use a torque wrench to tighten to at least the minimum torque setting given in the Table.</p>	<p><b>6</b></p>  <p>There may be gaps between the upper and lower nuts at this time and nut faces may not coincide. This is perfectly acceptable.</p>

Bolt Designation	Upper Nut Minimum Seating Torque (Nm)	Upper Nut Maximum Seating Torque (Nm)
M12	27	39
M16	70	100
M20	120	200
M24	160	300

Table 2 - Seating Torques (SS400 Grade Nuts Only)

**Maintenance Tightness Check on Hardlock Nuts must appropriate to the installation method. Excessive torques must not be applied to the upper nut.**

## 9 PAL NUTS – INSTALLATION AND TIGHTENING

PAL nuts require specific installation methods to be followed.

Providing the guidance for the installation of these nuts are followed, there is no requirement for a final check on the structural bolt positions. This is because the methods of installation in this document require tightness checks to be completed during the installation process

PAL nuts are fitted on top of a standard nut as a visual check that 2nd stage tightening has been completed. Due to its design, there is no need for either a flat or spring washer beneath the face of the standard nut.

Whilst the tower modules are on the ground, fit the bolt through the parts to be connected, then fit a standard nut and tighten using the 1st stage tightening guidance given above.

Once the tower has been lifted into position, providing a minimum period of one hour has passed since the initial tightening, the standard nut on each assembly should be checked for tightness, using the 2nd stage tightening guidance given above.

Fit the PAL nut onto the assembly and tighten using an open-ended spanner, until tight plus one half turn.

One Half turn of the Pal Nut is best confirmed by match marking the nut and Pal nut on opposite faces and tightening until the lines are coincident.

Pre-assembled tower modules will not have the PAL nut fitted when delivered to site. These should be fitted once the tower has been lifted into position and the standard nuts have been checked as above.

**Maintenance Tightness Check on PAL Nuts must be appropriate to the installation method. Excessive torques must not be applied to the PAL nut.**



Figure 1 - Example of Match Marking

**10 DESIGNERS STATEMENT OF RESIDUAL HAZARDS**

Design Residual Hazard	Description	Activity			
Loose Bolts	Bolts may remain or become loose if not adequately tightened during installation. Special care must be taken with modules that have been transported assembled as bolts may work loose during transit. Adequate and appropriate control measures must be in place to ensure connections are tightened correctly	Installation Maintenance			
Stripped threads or rupture of bolts.	Application of excessive force can lead to stripping of bolt threads or failure of the bolt. In particular, great care must be taken with Percussion Wrenches and Torque Wrenches. Maximum permissible values are listed in the adjacent table.	Installation Maintenance			
			Percussion Wrench and Torque Wrench Maximum Permissible Torque Settings		
			Bolt Size	Bolt Grade	
				4.6	8.8 & 10.8
			Torque Nm		
			M12	30	65
			M16	60	110
			M20	110	210
			M24	130	300
M30	180	450			
M36	280	700			
M42	400	1000			
Failure of locking mechanism	Incorrect tightening of locking nuts or special fasteners can lead to failure of the locking function. Appropriate tightening techniques must be used.	Installation Maintenance			

Table 3 - Designers Statement of Residual Hazards

A full risk assessment of each of the relevant identified hazards above needs to be completed by the inspector and/or maintainer.